



Country / City	United Kingdom / London
University / School	Kingston University London / Kingston School of Art
Academic year	2019/2020
Title of the project	Reconceptualising Brighton Seafront
Authors	Holta Deda

TECHNICAL DOSSIER

Title of the project	Reconceptualising Brighton Seafront
Authors	Holta Deda
Title of the course	MA Landscape and Urbanism
Academic year	2019/2020
Teaching Staff	Enrico Evangelisti, Íñigo Cornago Bonal, Kristof Fatsar
Department/Section/Program of belonging	Department of Architecture and Landscape
University/School	Kingston University London / Kingston School of Art



Written statement, short description of the project in English, no more than 250 words

Brighton represents an overly complex and dynamic cityscape within a dense urban area alongside the seafront. Very distinctive buildings across the seafront represent traces of the past and create a **collection of architectural features** infused with contemporary buildings. The prime examples of these features is the **Madeira Terrace**. All these unique urban elements host, at various times of the year, a wide range of cultural activities and are vital for the economy of the city.

Brighton also needs to **protect against the climate changes such as sea storms (causing flooding and soil erosion)** and the magnitude of population mobility between different seasons. Climate change is showing an increase in the water levels from **tidal activities** in the next 50-100 years of about 30-50 cm. These changes in sea levels will have a significant effect on the city and its ability to host social and economic events in the future.

This project will have a significant positive impact to retain the cultural and economic strength of the city with direct impact on the resident's standards of living and the tourism activity in the city. The proposed idea is based on **protecting and enhancing the seaside area** by combining the grey and green infrastructure with the Rip Rap stone technique. These stones are combined with effective local vegetation that serve not only as attractive features but as important elements of the public realm.

For further information
Máster d'Arquitectura del Paisatge -DUOT - UPC

T: +34 93 401 64 11 / +34 93 552 0842
Contact via email at: biennal.paisatge@upc.edu

Máster d'Arquitectura del Paisatge -DUOT - UPC
ETSAB- Escola Tècnica Superior
d'Arquitectura de Barcelona
Avenida Diagonal, 649 piso 5
08028 Barcelona-Spain



CLIMATE CHANGE AGAIN

11th International Biennial Landscape Barcelona

Barcelona September 2020
SCHOOL PRIZE



PROGRAM STRATEGY - ACTIVITIES & THE SHIFTING POPULATION

PEOPLE FREQUENCY AT EVERYDAY ACTIVITIES

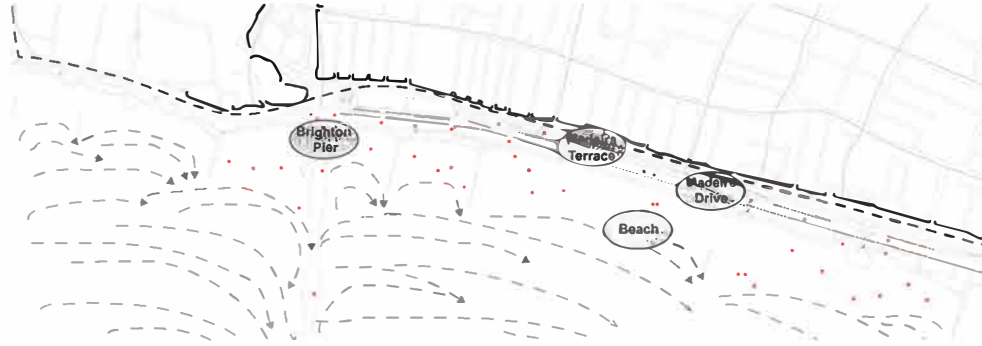

PEOPLE FREQUENCY AT SUMMER ACTIVITIES

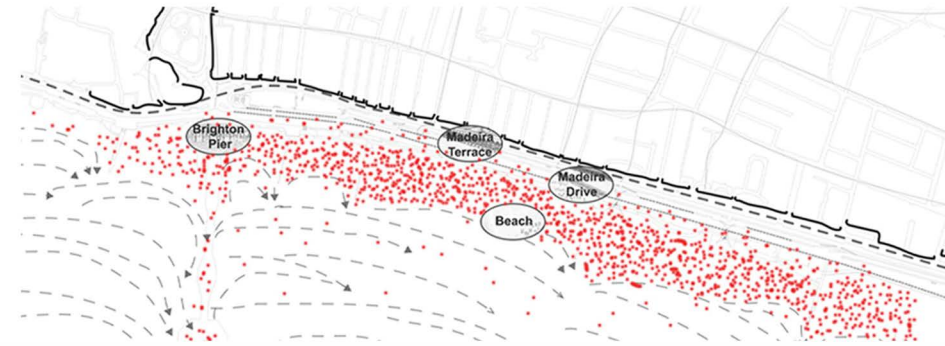

PEOPLE FREQUENCY AT MARATHON/RACING EVENTS

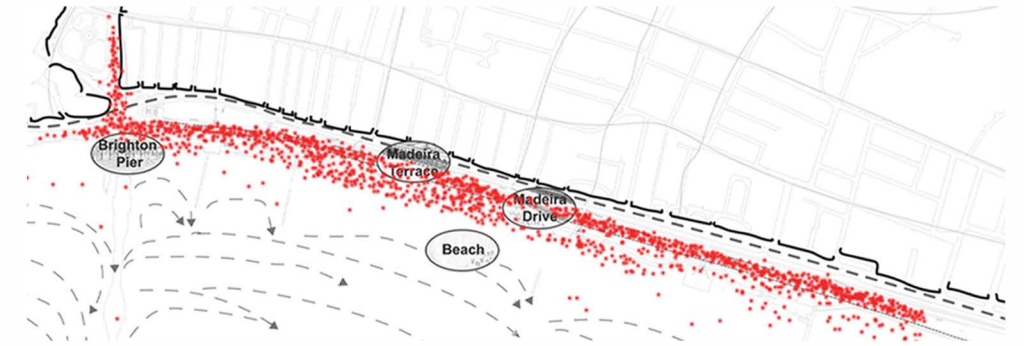

CONTEXT MAP

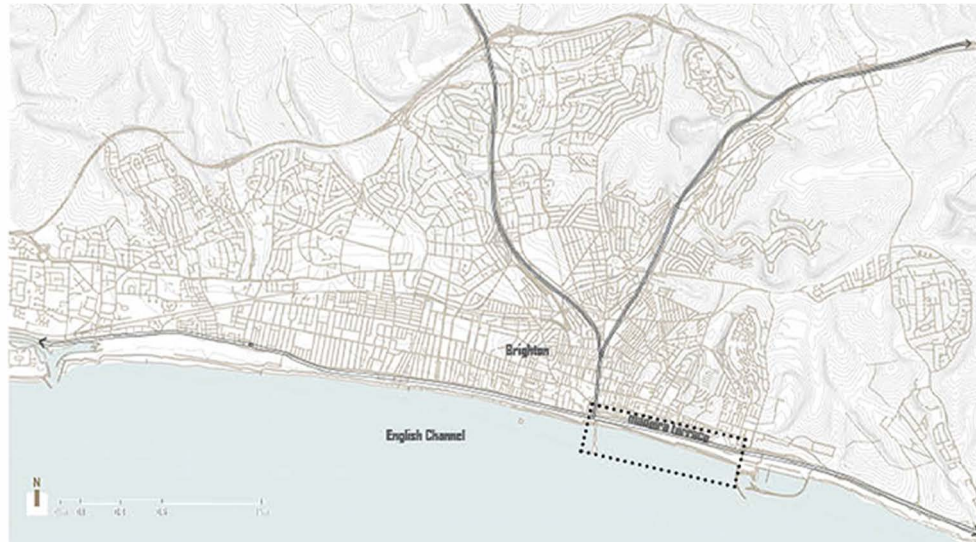

SEA LEVEL RISING, FLOODING, EROSION, STORM EVENTS WILL SHRINK THE EXISTING PLACE WHERE ALL THE ACTIVITIES THAT HAPPEN IN FRONT OF THE MADEIRA TERRACE.

ALL THESE UNIQUE URBAN ELEMENTS HOST, AT VARIOUS TIME OF THE YEAR, A WIDE RANGE OF CULTURAL ACTIVITIES AND ARE VITAL FOR THE ECONOMY OF THE CITY.

CONCEPT DIAGRAM - SOCIAL & NATURAL ACTIVITIES

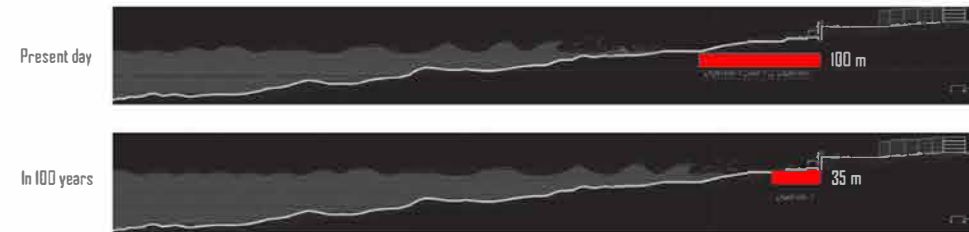

SCHEMATIC PROPOSAL CONCEPT

A PLATFORM THAT WILL REDUCE THE TIDES ACTIVITY AND THE EROSION PROCESS

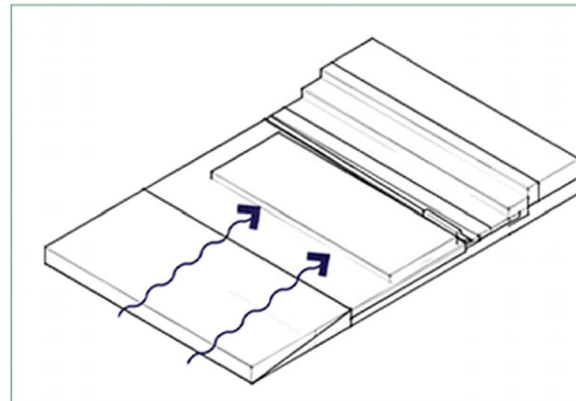

DIVIDE THE PLATFORM INTO SMALLER SECTIONS.

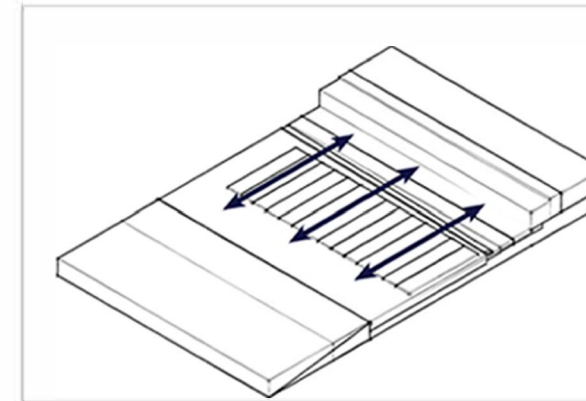

SHIFTING THE ELEMENTS.

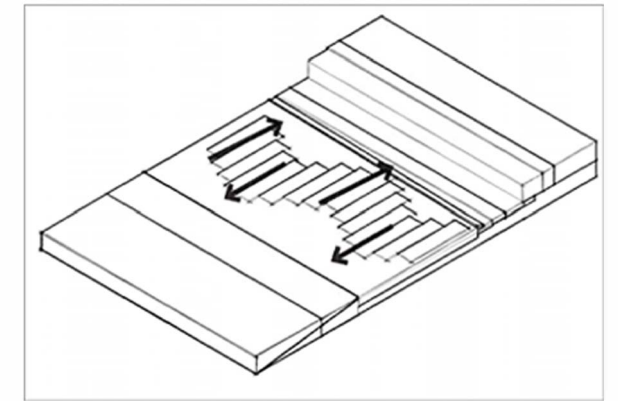

CREATING SMALLER SCALE OF THE ELEMENTS.

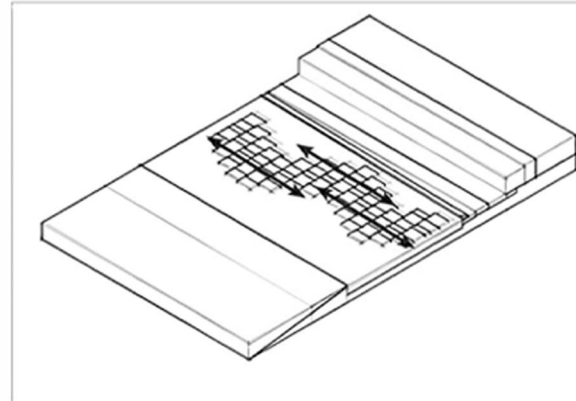

ELEVATING THE ELEMENTS VERTICALLY.

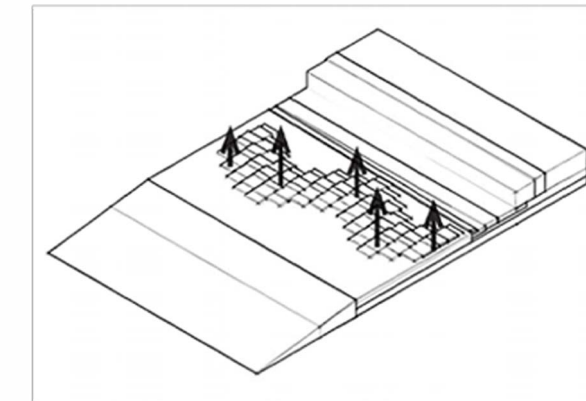

ENRICHING THE BACK OF THE ELEMENTS WITH VEGETATION. (PROTECTED FROM THE WIND).

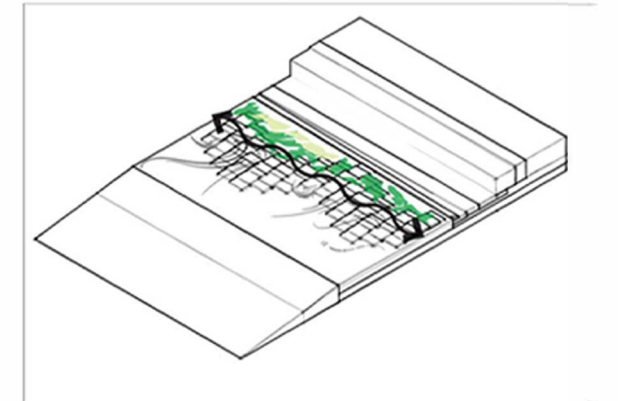



MATERIALITY, VEGETATION & USES

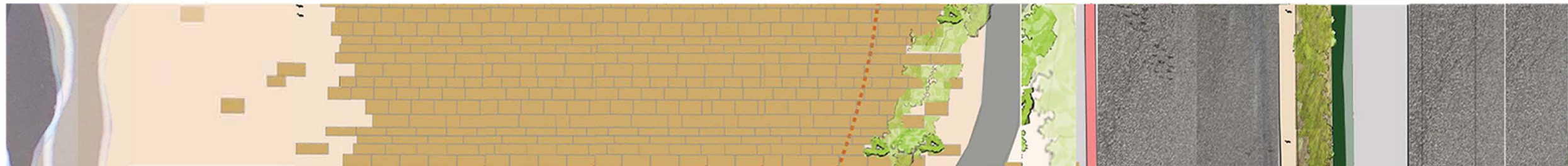
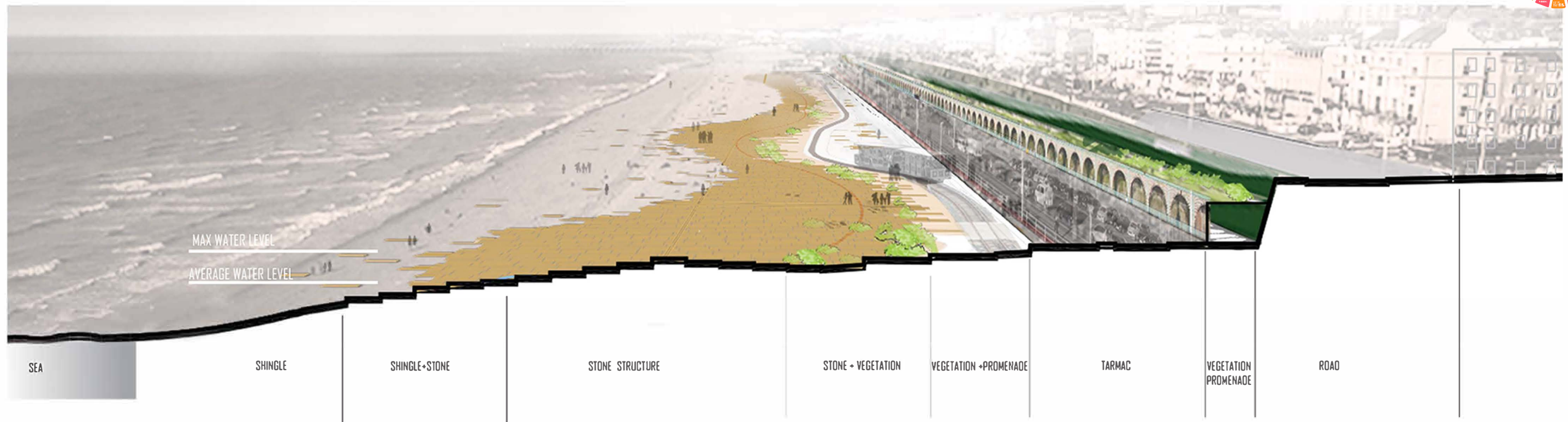

ELEVATION & PLAN

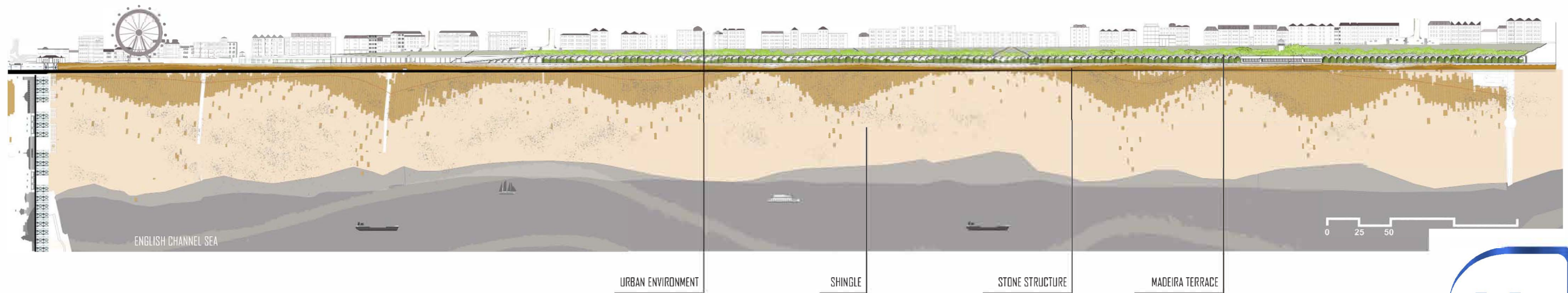



VIEW FROM THE MADEIRA TERRACE



PERSPECTIVE ON A TYPICAL DAY



PERSPECTIVE ON A MARATHON EVENT



PERSPECTIVE ON A STORM EVENT