



Country / City Italy / Florence

University / School University of Florence

Academic year 2018/2019

Title of the project Moovin' scape

Authors A. Desiderio, A. Filosofo, A. Parolin, A. Della Libera, A. Leonetti, A. Lunghi, A. Pecis, A. Lavanga, A. Lauria, D. Vignale, E. Mombelli, E. Acquasanta, F. Fumagalli, F. Caleffi, F. Todeschini, G. Premoli, G. Bagni, I. Rinaldi, J. Barelli, L. Iannizzotto, M. Ivagnes, M. Passera, M. Foroozesh, P. Galli, R. Mosconi, S. Micheloni, S. Messi, V. D'ippolito, V. Mamnone

TECHNICAL DOSSIER

Title of the project **Moovin' scape**
Authors A. Desiderio, A. Filosofo, A. Parolin, A. Della Libera, A. Leonetti, A. Lunghi, A. Pecis, A. Lavanga, A. Lauria, D. Vignale, E. Mombelli, E. Acquasanta, F. Fumagalli, F. Caleffi, F. Todeschini, G. Premoli, G. Bagni, I. Rinaldi, J. Barelli, L. Iannizzotto, M. Ivagnes, M. Passera, M. Foroozesh, P. Galli, R. Mosconi, S. Micheloni, S. Messi, V. D'ippolito, V. Mammone
Title of the course **Student Workshop**
Academic year **2018-2019**
Teaching Staff **Anna Lambertini, Francesco Ferrini**
Department/Section/Program of belonging **Architecture Department, Master's Degree course in Landscape Architecture**
University/School **University of Florence**



Written statement, short description of the project in English, no more than 250 words

Parklets are temporary public areas created from free space in car parks. They are meeting places, where you can stop to have a coffee, eat a sandwich during your lunch break or simply to relax from the chaos of the city. The criticism of the management of public space in the contemporary city very lively in Firenze, meets with a profound reflection, carried out within the Degree course in Landscape Architecture, on how a more focus and environmentally friendly design sensitivity is a strategic move for the sustainable development of the urban system. As citizens we believe that the city should have a pro-active approach to stress and this leads us to reflect on a new way of thinking and living spaces. As students of Landscape Architecture we think we can offer our contribution to make the urban environment more accessible and prepared for the effects of climate change. We tried to answer the question: "what can the landscape do for the city of the future? For this reason we investigated the theme of the rain garden and the spread of concreting"; With Park-let we aim to borrow space for vehicle mobility to return it to people and offer a different temporary urban scenario, which can sensitize citizens to a model attentive to the real and necessary transformations.



CLIMATE CHANGE AGAIN

11th International Biennial Landscape Barcelona

For further information
Máster d'Arquitectura del Paisatge -DUOT - UPC
T: + 34 93 401 64 11 / +34 93 552 0842
Contact via email at: biennial.paisatge@upc.edu

Máster d'Arquitectura del Paisatge -DUOT - UPC
ETSAB- Escola Tècnica Superior
d'Arquitectura de Barcelona
Avenida Diagonal, 649 piso 5
08028 Barcelona-Spain

Barcelona September 2020
SCHOOL PRIZE

CONCEPT

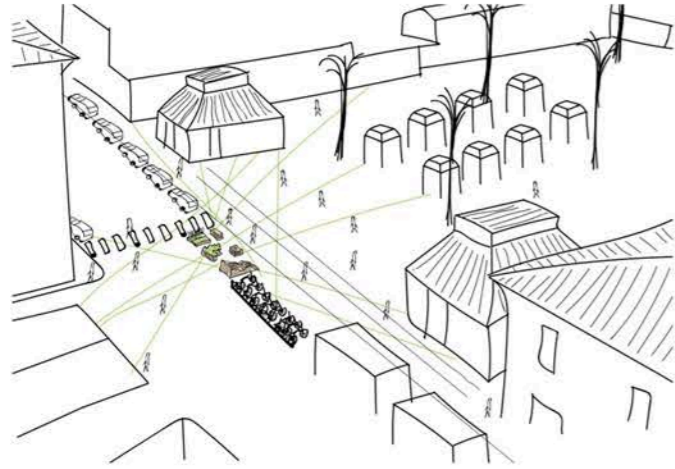

Benches

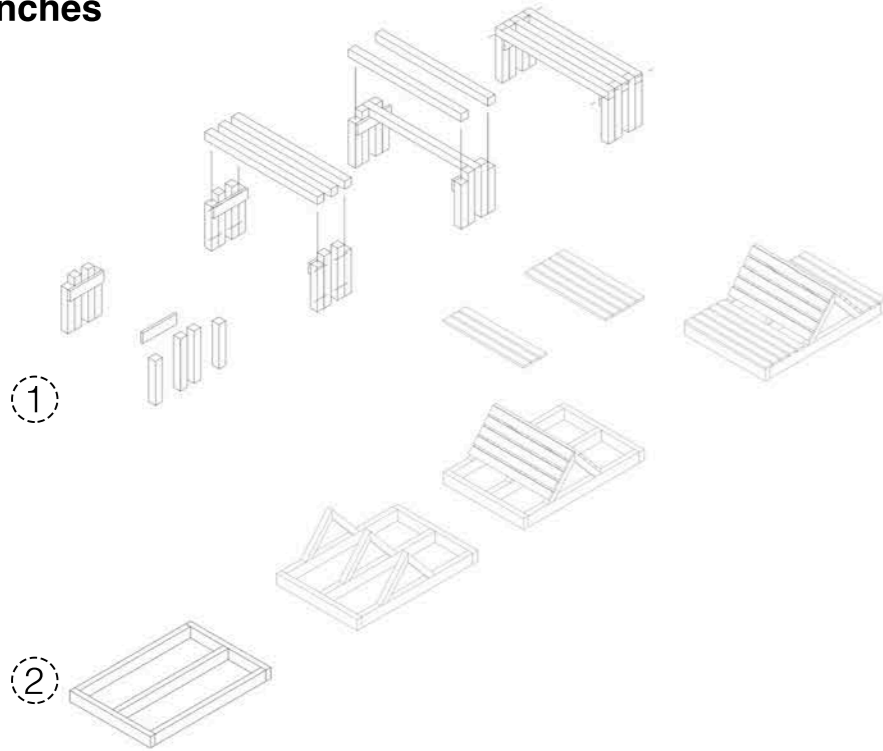

Rain garden cart

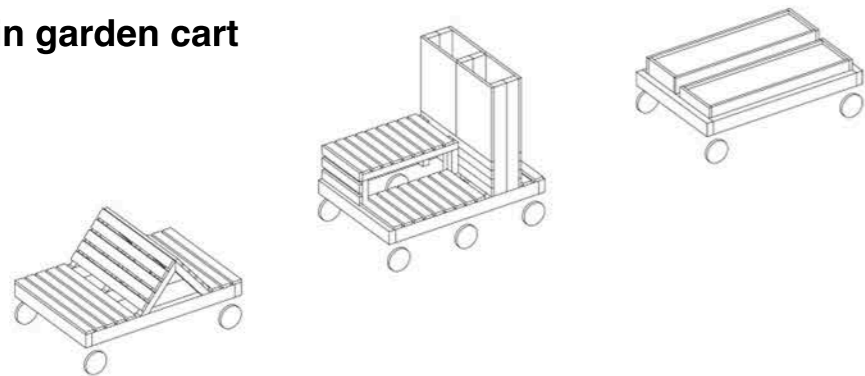

PARTICIPATED STUDENT DESIGN

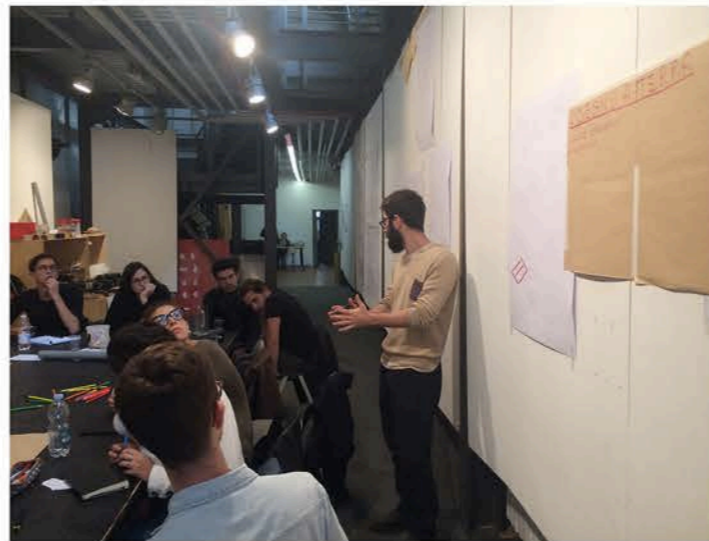

SELF CONSTRUCTION



FIRST EXHIBITION

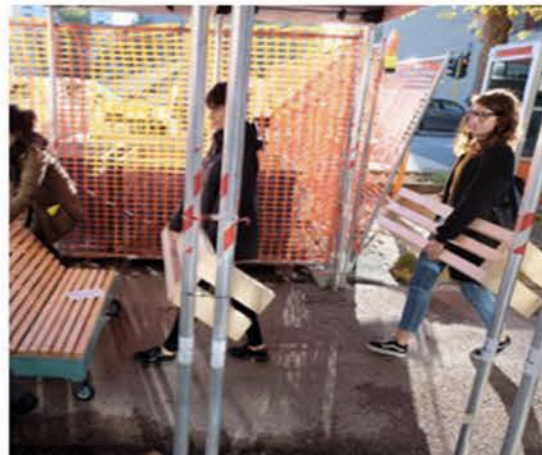
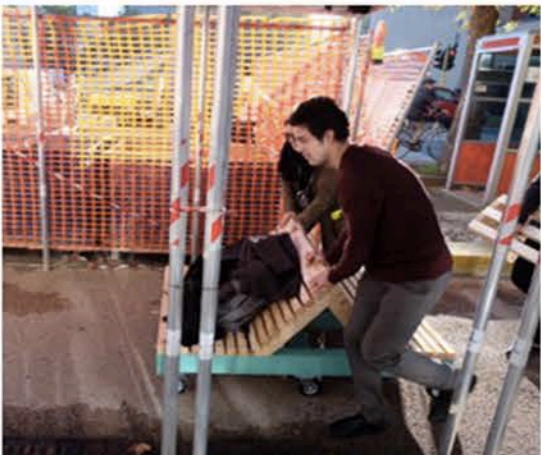

SECOND EXHIBITION

